

**PROPOSED FIRST FLOOR PLAN
SHOWING STRUCTURE OVER**

Scale 1:50

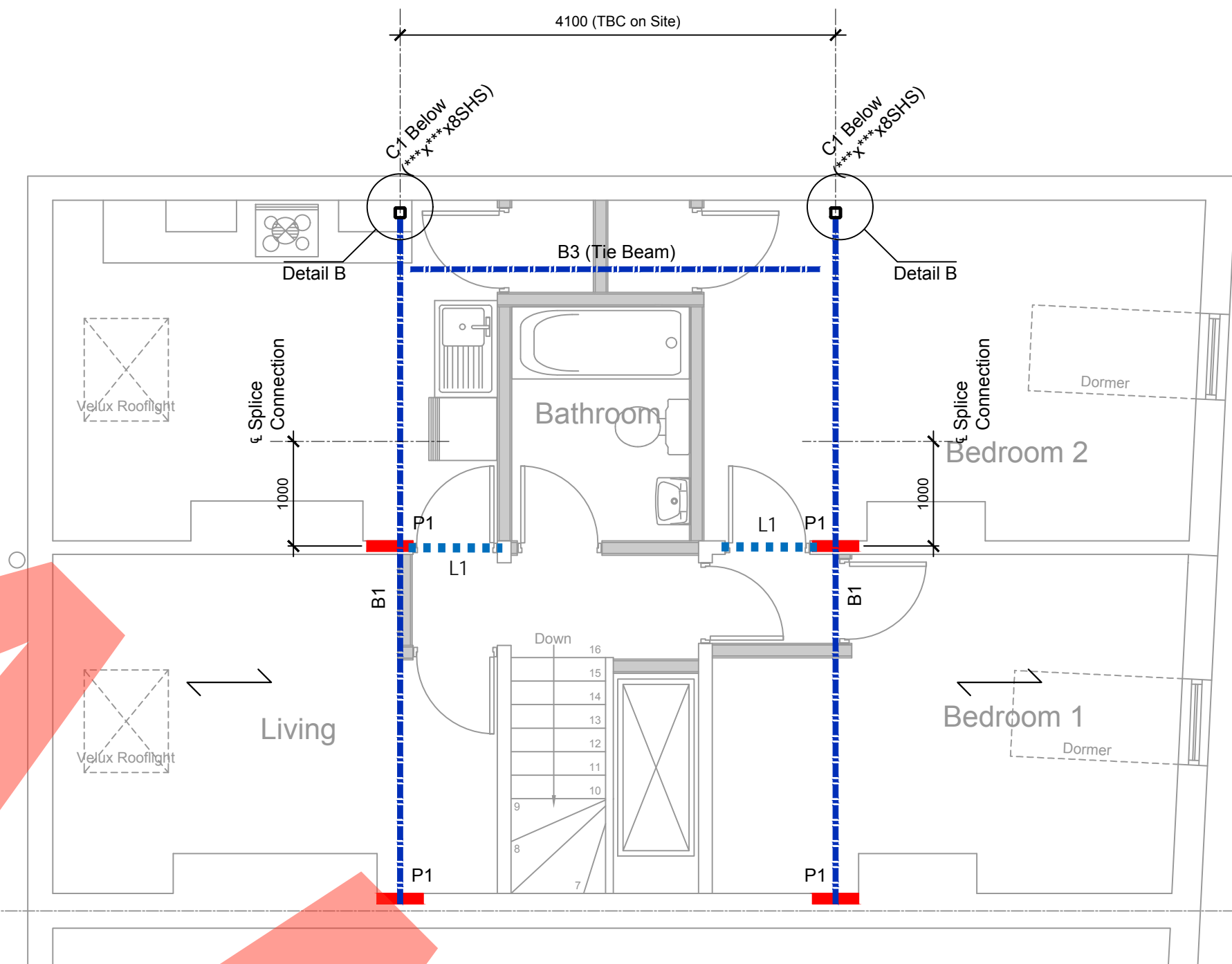

**PROPOSED SECOND FLOOR PLAN
SHOWING STRUCTURE OVER**

Scale 1:50

STEELWORK SIZES (Grade S355)
 B1 ***x***x**UB
 B2 ***x***x**UB
 B3 ***x***x**UB
 C1 ***x***x8SHS Post
 C2 ***x***x8SHS Post

KEY
 P1 440(l)x100(w)x215(d)
 C35 concrete padstone
 P2 300(l)x100(w)x140(d)
 C35 concrete padstone
 ← Assumed span of floor

NEW ROOF AND CAVITY WALL CONSTRUCTION TO BE IN ACCORDANCE WITH BUILDING REGULATIONS AND ARCHITECT DETAILS & RECOMMENDATION

All steelwork to be grade S355JR
 New brickwork to be 7.3N/mm² min Compressive Strength
 New brickwork to be 20N/mm² min Compressive Strength
 Mortar to be Class 4 above DPC and Class 6 below DPC
 Provide proprietary tension strapping at max. 1.5m c/c and framing anchors at wall / roof junction in accordance with Part A of The Building Regulations

ALL STEELWORK TO BE GRADE S355JR
ALL DIMENSIONS TBC BY CLIENT / ON SITE

ALL STEEL COLUMNS TO BE TIED INTO MASONRY USING PROPRIETARY METHODS. ANCON FRAME CRAMPS AT 225mm CENTRES, OR SIMILAR APPROVED.

ALL SECOND FLOOR INTERNAL WALLS ARE ASSUMED TO BE A LOAD BEARING WALL - TBC ON SITE

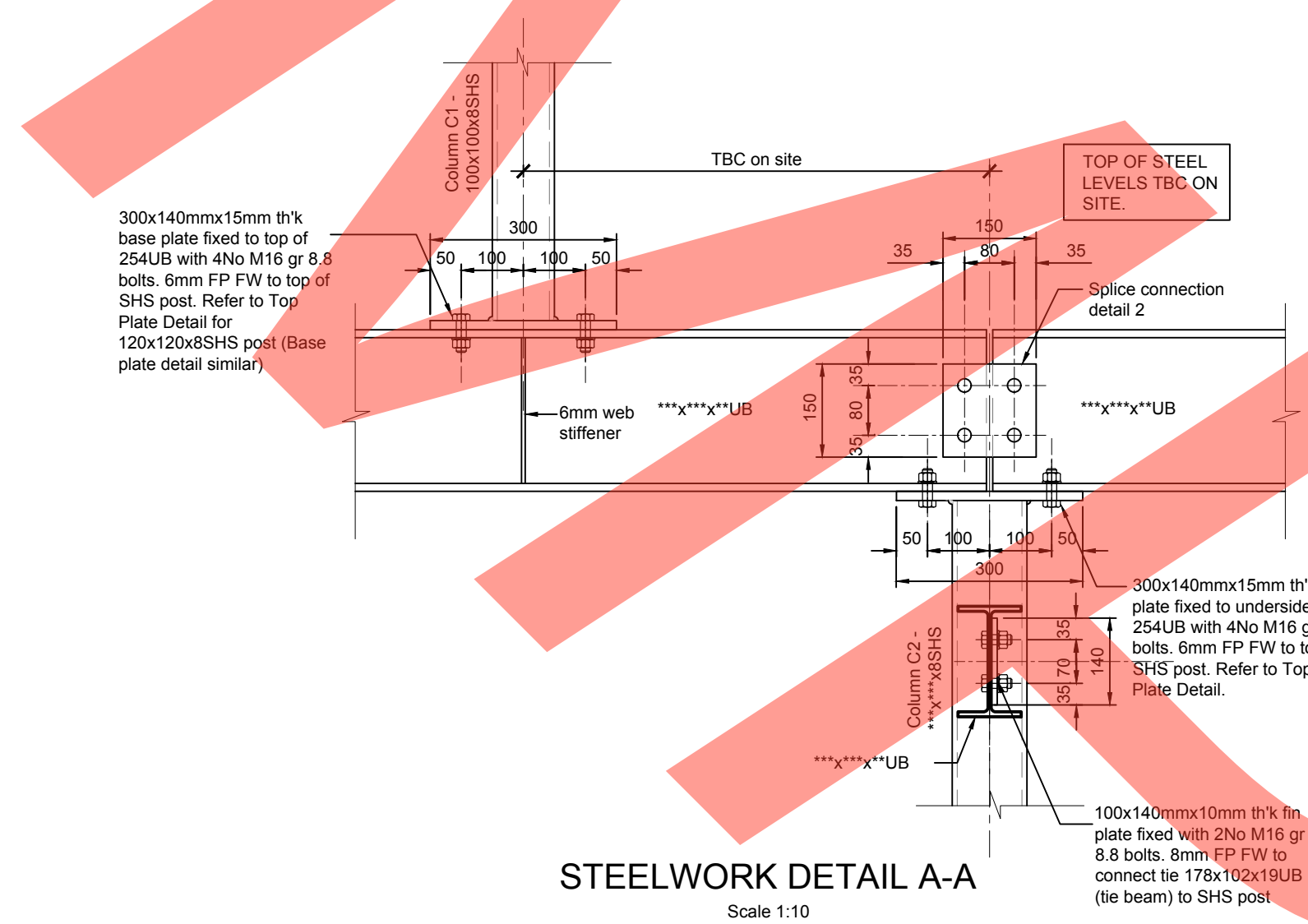
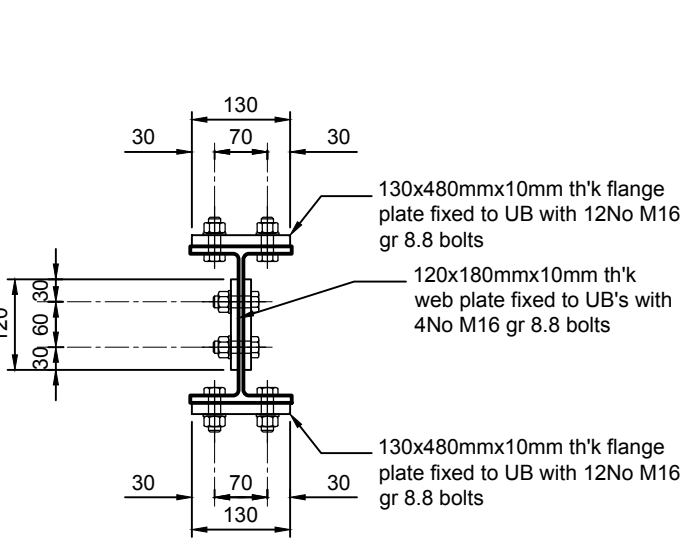
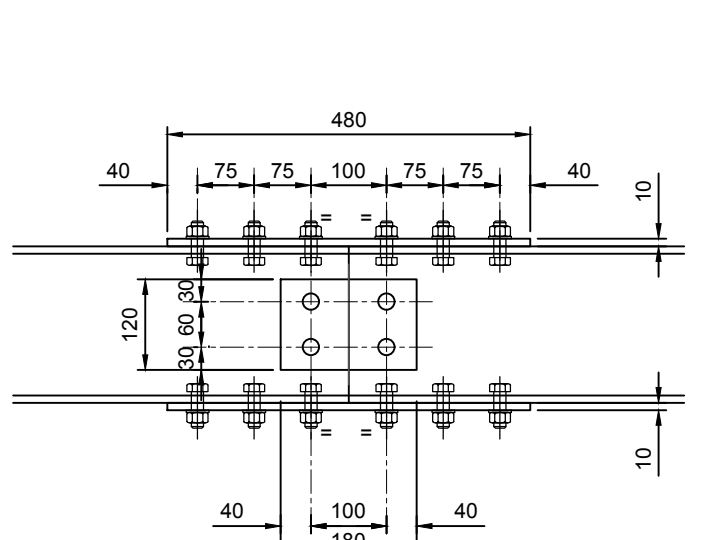
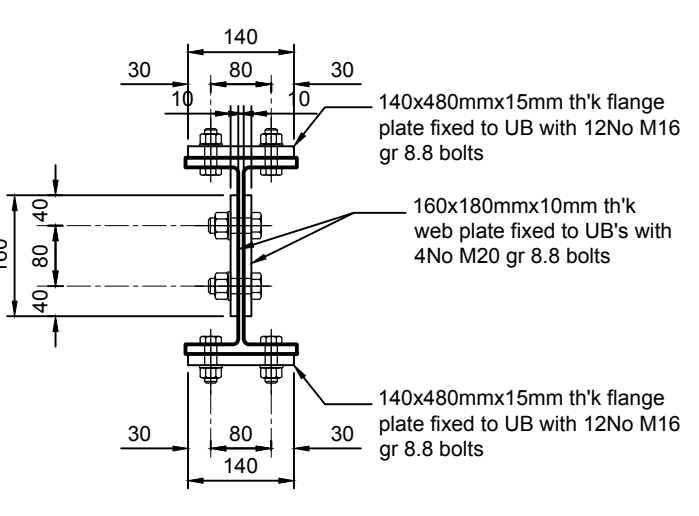
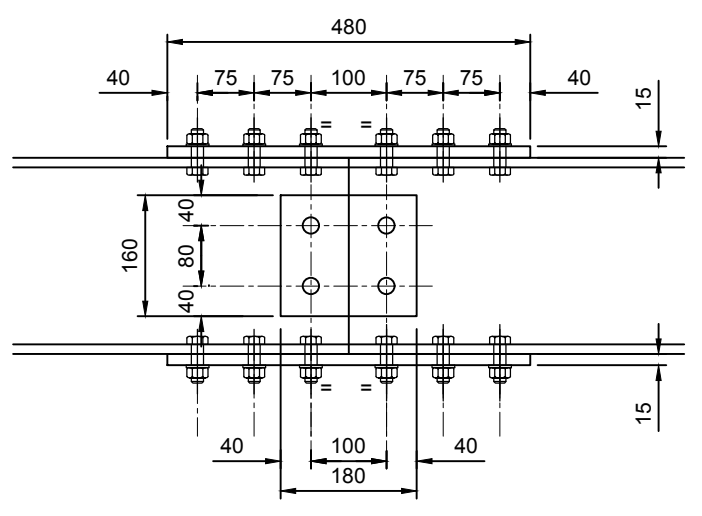

STEELWORK DETAIL A-A
Scale 1:10

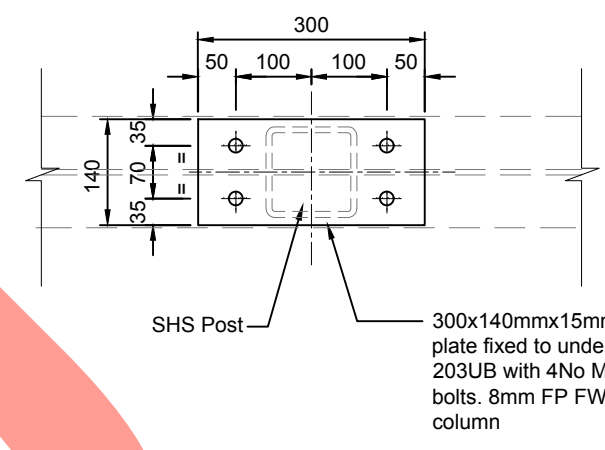

TOP PLATE DETAIL FOR *x***x8SHS POST**
Scale 1:10

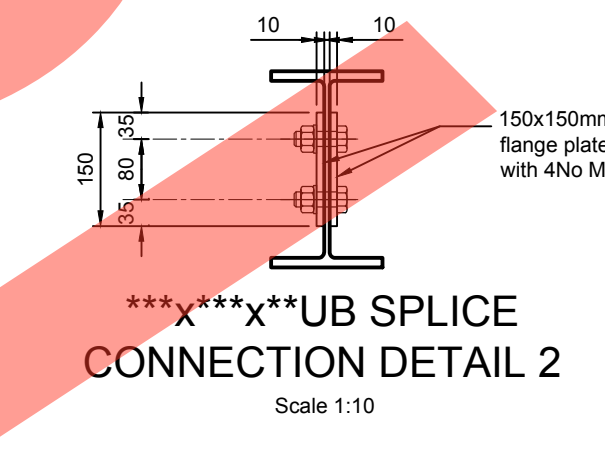

*****x***x**UB SPLICE CONNECTION DETAIL 2**
Scale 1:10

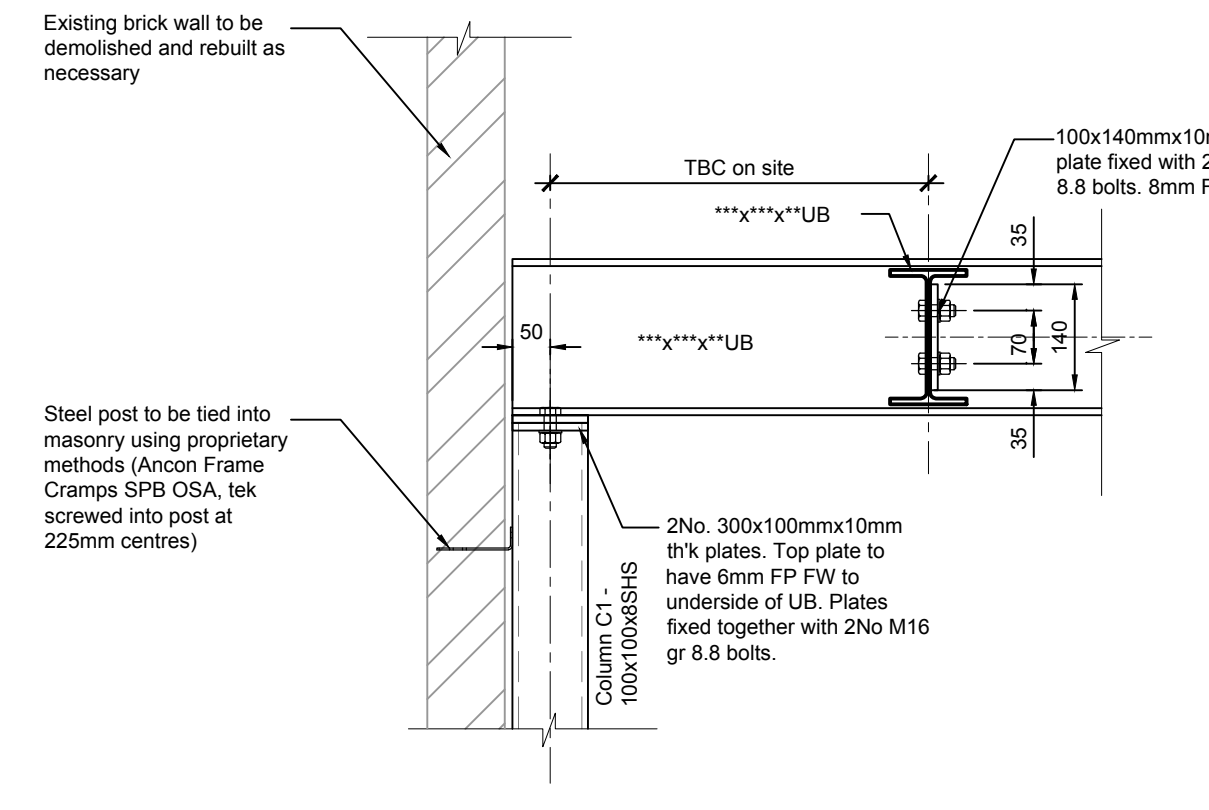

STEELWORK DETAIL B
Scale 1:10

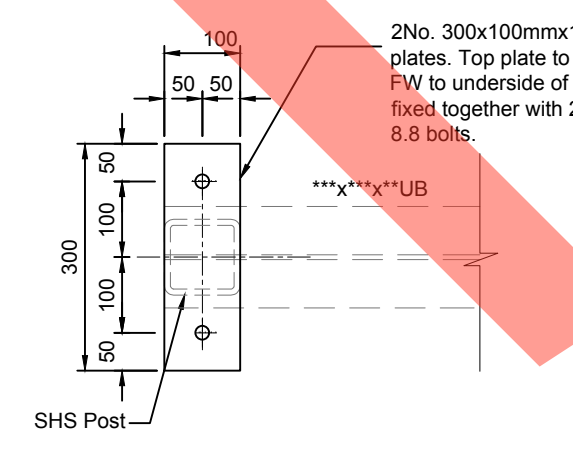

TOP PLATE DETAIL FOR *x***x8SHS POST**
Scale 1:10

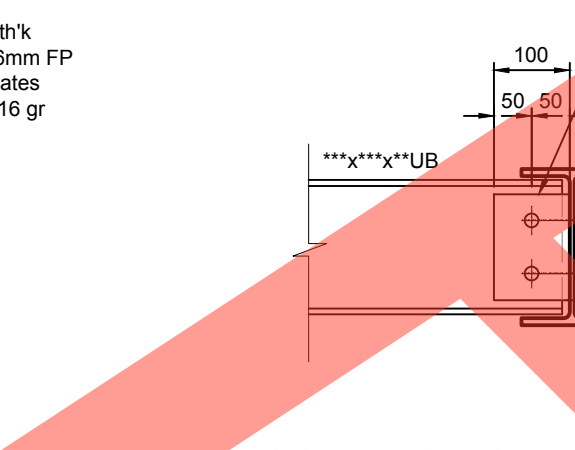

CONNECTION DETAIL *x***x**UB (B3) : ***x***x**UB (B1)**
Scale 1:10

- GENERAL NOTES**
- Any discrepancies between the drawings or documents shall be brought to the attention of the Engineer before placing orders or commencing construction.
 - The drawings shall not be scaled; use only figured dimensions.
 - Dimensions and conditions shall be verified on site. Variations between the drawings and site conditions shall be brought to the attention of the Engineer for resolution before placing orders or commencing construction.
 - All work shall comply with the Building Regulations and the requirements of the Local Authority, current Codes of Practice and British Standards.
 - All workmanship shall be first class trade practice and to the recommendations given in BS8000: Basic Workmanship.
 - Do not use: high alumina cement; wood wool slabs; calcium chloride as an admixture; asbestos products; sea dredged aggregates; aggregates subject to alkali silica reaction or which do not comply to BS8110; materials containing fibres with a diameter of less than 3 microns and length less than 200 microns; any unsealed fibre materials; lead products in plumbing or drainage; urea formaldehyde; calcium silicate bricks and tiles; slip bricks; lead based paints; vermiculite plaster or any material considered to be deleterious or harmful to health.
 - Take all measures necessary to ensure the safety and security of operatives and the integrity of adjoining structures and roads or walkways.
 - This drawing is to be read in conjunction with all relevant drawings and specifications.
 - All dimensions are to be confirmed by the contractor on-site prior to construction. The Contractor is to satisfy himself that dimensions, levels etc. are sufficiently accurate and complete for fabrication, within the specified tolerances of all prefabricated elements.
 - All works to be undertaken by an experienced and competent contractor in accordance with the current Building Regulations Part A, British Standards and good working practice.
 - All temporary works / Propping to the contractor's design and details. The main contractor shall be entirely responsible for the stability of the structure whilst the works are in progress. Due regard shall be given to lateral stability of elements in the addition of support of vertical loads when construction has the need for temporary support works.
 - To minimise deflections of the existing structure, new beams must be pinned upright to existing construction with slate or dry-pack mortar, and all mortar allowed to cure prior to de-propping.
 - Due to significant structural works, minor post-construction deflection of brittle finishes may be expected in the existing building.
- Steelwork**
- All connections to Fabricator's details. The main contractor and the steelwork sub-contractor will be responsible for agreeing all holes and fixings in the steelwork required by specialists and sub-contractors supplying secondary elements and incorporating these in their shop drawings.
 - Steelwork in cavity to receive 2No. coats of bituminous paint.
 - Fabrication drawings to be submitted to supervising engineer for comment 10 days prior to fabrication of steelwork.
 - Erection shall be carried out so that the partially completed structure is stable and has an adequate factor of safety at all times. The contractor shall submit a method statement prior to commencing erection.
 - All steelwork to be minimum grade S355JR to BS EN 10025:1993 unless noted otherwise, execution class 2 & CE marked.
 - All steels that support timber work are to have the flanges pre-drilled @ 500mm centres to accept timber plates.
 - External steelwork to be galvanneal.
 - All connections to have a minimum 2No M16 grade 8.8 bolts. 6mm full profile fillet welds & 10mm thick end plates unless noted otherwise.
 - All loose beams to have a minimum bearing length of 150mm to parallel walls and 100mm to perpendicular walls and 440x100x215mm deep concrete padstones unless noted otherwise. 2No. M10 Resin Anchor locating bolts or similar approved to connect beam to padstone.
 - All beam ends to be painted with 2No. coats bituminous paint where embedded.
 - All steelwork below dpc to have a minimum 100mm concrete encasement to foundation specification or be painted with two layers bituminous paint.
 - All base plates to be minimum 20mm thick with 4No M20 minimum grade 8.8 HD bolts unless noted otherwise.
 - Beams and lintels to have a minimum bearing length of 100mm when perpendicular to the wall, and 200mm when parallel to the wall unless noted otherwise.
 - Fire protection to be in accordance with relevant Building Regulations and Architect's details. New steel beams to be fire protected using British Gypsum Gyproc Fireline Pink plasterboard or 2 layers of plasterboard and skim to achieve minimum 30 minutes to 1-hour fire protection.

Rev.	By	Date	Details	Chkd

Drawing Status: PRELIMINARY



Enterprise Centre,
6 David Lane
Basford,
Nottingham

e: daniel@iktconsulting.co.uk
 w: www.iktconsulting.co.uk
 m: 07950477550
 t: 01158493447

Client: ***** Development LTD

Project: Proposed Structural Alterations at
 ** Bath Street,
 Ilkeston,
 DE7 8AJ

Title: Proposed Steelwork Layouts and Details

Scale (A1)	Drawn by	Dr. No.
1:10/1.25/1.50	BC	
Date	Checked by	
21.07.21	DI	IKT0000_002